

picoUPS-120-ATV

12V DC battery backup system
Micro UPS (uninterruptible power supply)

Quick Installation Guide

Version 1.0b
www.short-circuit.com
SKU: 120010



Introduction

The **picoUPS-120-ATV** is a small yet powerful UPS (uninterruptible power supply) solution. The **picoUPS-120-ATV** was conveniently design to be compatible with quarter brick PSU standard (58 x 36mm).

The **picoUPS-120-ATV** ensures uninterrupted power for your electronics by automatically switching in between a DC input source (13-18V) and a Lead Acid (SLA battery). The switching in between the power sources is instantaneous, thus allowing smooth, uninterrupted device operation. The **picoUPS-120-ATV** also has a built-in, 1.2A fast charger unit. Because of its low V_{in} charging capabilities, the **picoUPS-120-ATV** has been optimized for vehicle use.

Mode of Operation

The **picoUPS-120-ATV** has been specifically designed for uninterruptible small/medium power PC operation, where “always on” operating is required. Applications for the picoUPS include a wide range of systems including servers and telecom and high availability systems or for powering electronics in vehicle applications. For example, the V(in) of the **picoUPS-120-ATV** can be plugged into a vehicle cigarette lighter, while V(out) provides an uninterrupted power source selected from either cigarette lighter or the backup battery.

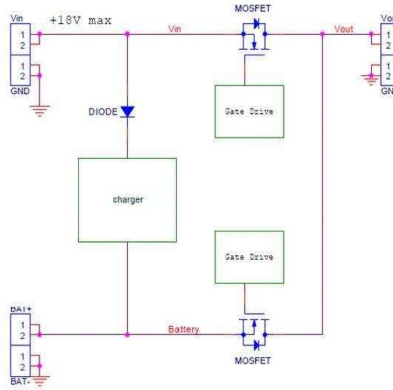

Fig 1.1 *picoUPS-120-ATV* block diagram

Power inputs

- 1) A 13-18V power source. (13.5V – 16V ideal) NOTE: Unit will work as low as 6V, but battery will not be charged if V(in) is lower than 13V!
- 2) A Lead Acid or Sealed Lead Acid battery (4Ah-60Ah)

Power Path Switching

The **picoUPS-120-ATV** will automatically switch in between V(In) and Batt depending on who has a higher voltage. The switching hysteresis is as low as 10mv. As a result, when AC/DC power is lost, the picoUPS will automatically switch to Battery output. The switching speed is about 100nS. When powered from main source, V(in) a green LED will light up indicating that the main power source path is ON.

Battery charging, bulk charging mode

The **picoUPS-120-ATV** has a built in, fast 1.2A, constant current, constant voltage, SLA battery charger. Depending on battery size and level of discharge, charging stage can be anywhere from few minutes to few hours. For example, a typical 7AH / 12V SLA battery will fully charge in 6 hours. When the battery is near full capacity, charge current will slowly decrease.

Typical configuration

A typical configuration for a low / medium power computer setup is comprised from a 12V / 7Ah battery, a 13.5V from a vehicle. The output can be coupled to ATX power supply such as M1-ATX, M2-ATX, M3-ATX, M3-ATX-HV.

Specifications

Power Ratings (max load = 10A)

Volts (V)	Max Load (A)	Peak Load (A)	Max Charge Current
6-18V*	6A fanless / 10A fan	12A	1200mA**
<small>* if Vcc is below 13-13.5V unit will work but will not fully charge the Battery. ** Charge current can be modified by changing the current sense resistor , R22, R20: R(sense)=0.1R I(lim)= 600mA R(sense)=50mR I(lim)=1200mA (default) R(sense)=25mR I(lim)=2400mA Precautions for operating this DC-DC converter: -Inrush input current should not exceed 20A. -Peak load should not exceed 60 seconds. -Idle current: < 6mA. For standby periods exceeding 30 days, min. battery size should be 7Ah. -Float voltage is 13.5V (+/-1%). Use only with SLA or LifePo4 (4 pack) -Low voltage battery cut-off not provided by this module.</small>			

Input Requirements: 13-18V regulated, min=2A, max = load dependent.

Fuse: Blade, 10A Size: 58mm(L) * 36mm(W) * 20mm (H) (1U compliant)

Weight: 30 grams

Connectors: Faston Blades, 0.187'

Overload protection

This unit does not provide overload protection. Inrush current should not exceed more than 20 A for 1 second.

Operating environment

Temperature: -20 to 65 degree centigrade.

NOTE: For fanless operation, please ensure that the PSU body temperature, T(psu) does not exceed 75C. Higher temperatures are allowed, but MTBF could decrease. Maximum power supply body temperature T(psu) is 85C.

Relative Humidity: 10 to 90 percent, non-condensing.

Efficiency, MTBF: 95%. MTBF=100K hours at T(psu) 55Celsius.

Shipping and storage

Temperature -40 to +40 degree centigrade. Relative humidity 5 to 90 percent, non-condensing

Warranty

1 Year Limited Warranty statement. Warranty is void if maintenance or calibration is performed by end-user or by use in conjunction with power modules not provided by short-circuit.com.

Support

Web Site: <http://www.short-circuit.com/support.html>