

M2-ATX

6-24V Intelligent Automotive ATX Power Supply

www.short-circuit.com

Installation Guide

Version 1.0

P/N 100006

Before you start...

Please take a moment and read this manual before you install the M2-ATX in your vehicle. Often times, rushing into installing the unit can result in serious damage to your M2-ATX board, computer and probably your car's electrical system.

The M2-ATX board has several wires that need to be installed in various places. When installing, **always double check the polarity** of your wires with a voltmeter.

Avoid using the cigarette plug as a power source, often times the contacts are not capable of delivering high current to your PC.

1.0 Introduction

Thank you for purchasing the M2-ATX power sequencer / vehicle ATX power supply.

The M2-ATX was designed to work with a wide variety of main boards such as the VIA mini-ITX motherboards as well as Pentium-M, Celeron or full power P4 systems.

1.1 M2-ATX Logic Diagram

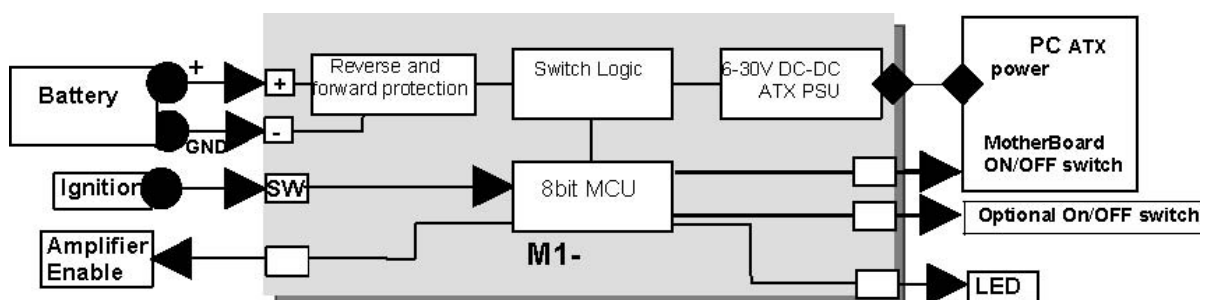

1.2 M2-ATX Connection Diagram

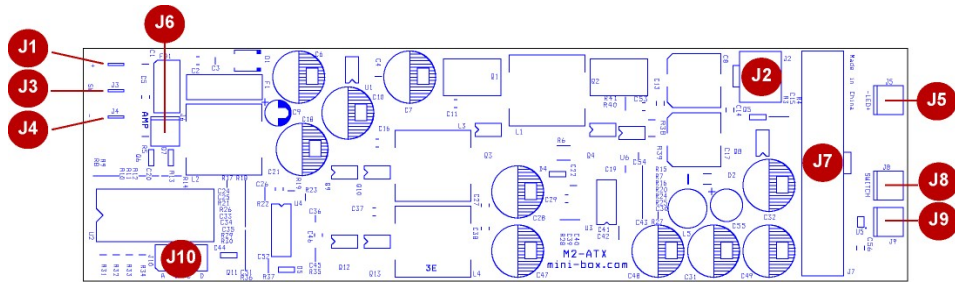

M2-ATX, top view

Power Input Connectors

- J1** Battery + (un-switched battery, positive)
- J3** Ignition (switched battery, positive. Can test by connecting it to Battery +)
- J4** Battery -(negative)

Controls and Settings

- J6** Controls amplifier via remote ON/OFF. Left pin is RMT, Right pin is GND
- J8** To motherboard ON/OFF switch
- J10** User jumper settings (A,B,C,D)
- J9** To external ON/OFF switch (optional, J8 is in parallel with J9)

Power Output Connectors

- J2** Optional P4-12V power
- J7** ATX power connector (to motherboard)
- J5** To LED (optional)

A	B	C	D	MODE	OFFDELAY / HARDOFF
□	□	□	□	0	(traditional PSU mode)
■	□	□	□	1	5sec / 45sec
□	■	□	□	2	5sec / 2hour (suggested)
■	■	□	□	3	5sec / never
□	□	■	□	4	30sec / 2hour
■	□	■	□	5	30sec / never
□	■	■	□	6	30min / never, (taxi mode)
■	■	■	□	7	3hour / never, (taxi mode)

NOTE: If HARDOFF is set to "never", the M2-ATX will automatically shut down when battery voltage is below 11.2V for more than 1 minute in order to prevent 'deep discharge' situations.

Mode "0" is regular ATX power supply mode, no power sequencing provided, can be used for non vehicle applications.

Avoid using HARDOFF = never, can severely discharge your battery if PC. Suggested modes are: 1, 2, and 4.

1.2 Power challenges in a Vehicle PC

The 5V Standby Problem: One of most difficult tasks of operating a PC in a vehicle is power consumption while the computer is OFF. Even when your computer is OFF, it will still consume about 100mA on the 5V rail. All power supplies provide 5VSB (5V standby) so that the motherboard can issue at least a PSON signal. When the computer is in the suspend mode, it will consume even more power, because the RAM needs to be powered at all times.

No matter how big your battery is, it will eventually drain your battery in a matter of days.

The M2-ATX is addressing these issues by cutting off the 5VSB rail after a pre-defined amount of time (see jumper chart, HARDOFF). When 5VSB is always active (HARDOFF=Never), M2-ATX constantly monitors the battery levels. When battery level

drops below 11V for more than one minute, M2-ATX will shut down and re-activate only when the input voltage is > 11V.

Engine Cranks, under-voltage and over-voltage situations. Another difficult task is maintaining stable 3.3V, 5V, 12V and -12V power to your PC. While car batteries are rated at 12V, they actually provide voltages in between 7-11V (engine cranks) or as high as 80 volts (load dump). Most of the times, your battery will stay at 13.5V (while car is running) but extra precautions need to take place in order to prevent such situations. M2ATX can operate as low as 6V and as high as 28V while providing strict regulation on all rails along with input voltage clamping and reverse protection.

Loud amplifier pops when PC starts. If your PC is connected to your car amplifier, you will hear a loud pop when the computer is first started. The M2-ATX has an 'anti-thump' control that will keep your amp OFF while the PC starts. Simply connect J6 to your amplifier remote control pins to activate the 'anti-thump' feature.

2.0 Mode of operation

The M2-ATX performs several timing routines and takes actions as follows:

(NOTE: When all config jumpers are removed, M2-ATX will be in the "dumb PSU mode", no ignition timing, no HARDOFF. M2-ATX will send a gratuitous "ON" pulse to the M/B when power is applied for the first time. Do not connect J8/J9 to the M/B on/off switch if you don't want your PC to be started automatically.)

1. Ignition=OFF. Nothing happens. M2-ATX is waiting for ignition signals.
2. Ignition=ON. M2-ATX waits for 2-3 seconds then turns on the 5Vsb rail. After another second M2-ATX sends an "ON" signal to the motherboard via the 2 wires connected to the motherboard's ON/OFF pins. The motherboard will turn ON and your system should start booting.
3. Ignition=ON during driving. Your computer will remain ON.
4. Ignition=OFF. M2-ATX waits for "OFFDELAY" in seconds (see jumper chart on Page 2) and then it turns the motherboard OFF by sending a signal to the motherboard's ON/OFF switch. Your computer should turn off gracefully (shutdown procedure). During this time, power will still be available for your PC to perform shutdown.
5. 5VSB will still be provided for another "HARDOFF" seconds (see jumper chart). In the event where the shutdown process is longer than "OFFDELAY" (windows gets frozen, etc), power will be shut down hard, turning off all power rails. If "HARDOFF" is set to 'NEVER', the PSU will always provide 5VSB, therefore the PC can also be used in the SLEEP mode. During the HARDOFF procedure, the battery levels will be constantly monitored to prevent deep discharge situations.
6. M2-ATX will go to step 1, if ignition is tuned ON again.

3.0 Troubleshooting

Motherboard is not turning ON

- Check input cables. Measure voltage on the un-switched 12V. You should get about 12V. Measure the un-switched pin (red) while turning the car ON/OFF. You should see 12V (car on) or 0V (car off).
- Check your output cables. Ensure total system power consumption does not exceed the M2-ATX specifications.
- Make sure that either J8 or J9 is properly connected to the ON/OFF switch of your M/B.

4.0 M2-ATX Characteristics

Minimum Input Operating. voltage	6V
Maximum input Operating voltage	24V (clamping will occur at 25-27V)
Deep-Discharge shutdown threshold	11.2V
Input current limit (fuse protected)	15A (15A mini-blade fuse)
Max Output Power	160 Watts
Operating temperature	-40 to +85* degrees Celsius
Storage temperature	-55 to +125 degrees Celsius
MTBF	192,000 hrs @ 50C, 96,000 hrs @65C
Efficiency (Input 9-16V)	>94%, all rails combined, 50% load.
PCB size	160x45mm
Input connectors	Faston 0.25" terminal
Output Connector	ATX Power 20 pin (Molex P/N 39-01-2200)

*Units starts failing at ~115 Celsius. Operating at temperatures above 85C / 185F will drastically reduce the MTBF. When operating at high temperatures or fanless operation, must reduce PSU load by 25%.

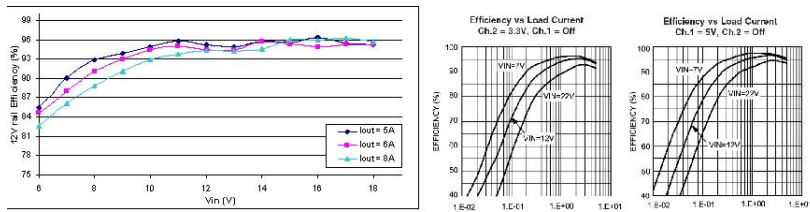

Maximum Power Characteristics

Output Rail	Current (Max)	Current Peak (<60s)	Regulation
5V	8A	12A	1.5%
3.3V	8A	12A	1.5%
5VSB	1.5A	2A	1.5%
-12V	0.15A	0.2A	5-%
12V	8A* (see below)	9A	2%

Total power = 169.9 Watts

When operating at 24V or extreme temperatures, de-rate by 25%, ventilation will be required.

12V Rail Output Current

Input (V)	12V rail current	Input (V)	12V rail current
6V	4A	11V	8A
7V	5A	12V	8A
8V	6A	14V	8.5A
9V	7A	14-18V	9A
10V	8A	20-26V	7A

For low input voltage (6-10V) ventilation might be required for peak load

5.0 Support and Warranty

Standard Hardware Warranty 1 year / US

Installation Support: 30 days via email: support@short-circuit.com